

**NOTES:**

1. COAT INTERIOR OF RECEIVING AND NEXT DOWNSTREAM MANHOLES WITH LEVEL C LINING SYSTEM 250 MILS MINIMUM THICKNESS.
2. SEE TRACER WIRE AND MAGNETIC TAPE DETAIL FM-002 FOR ADDITIONAL INFORMATION.

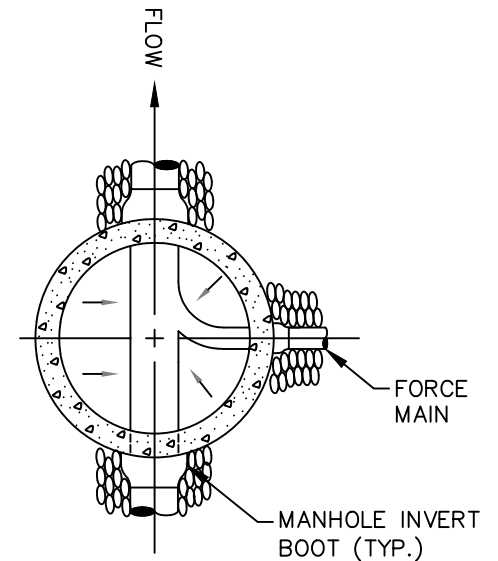
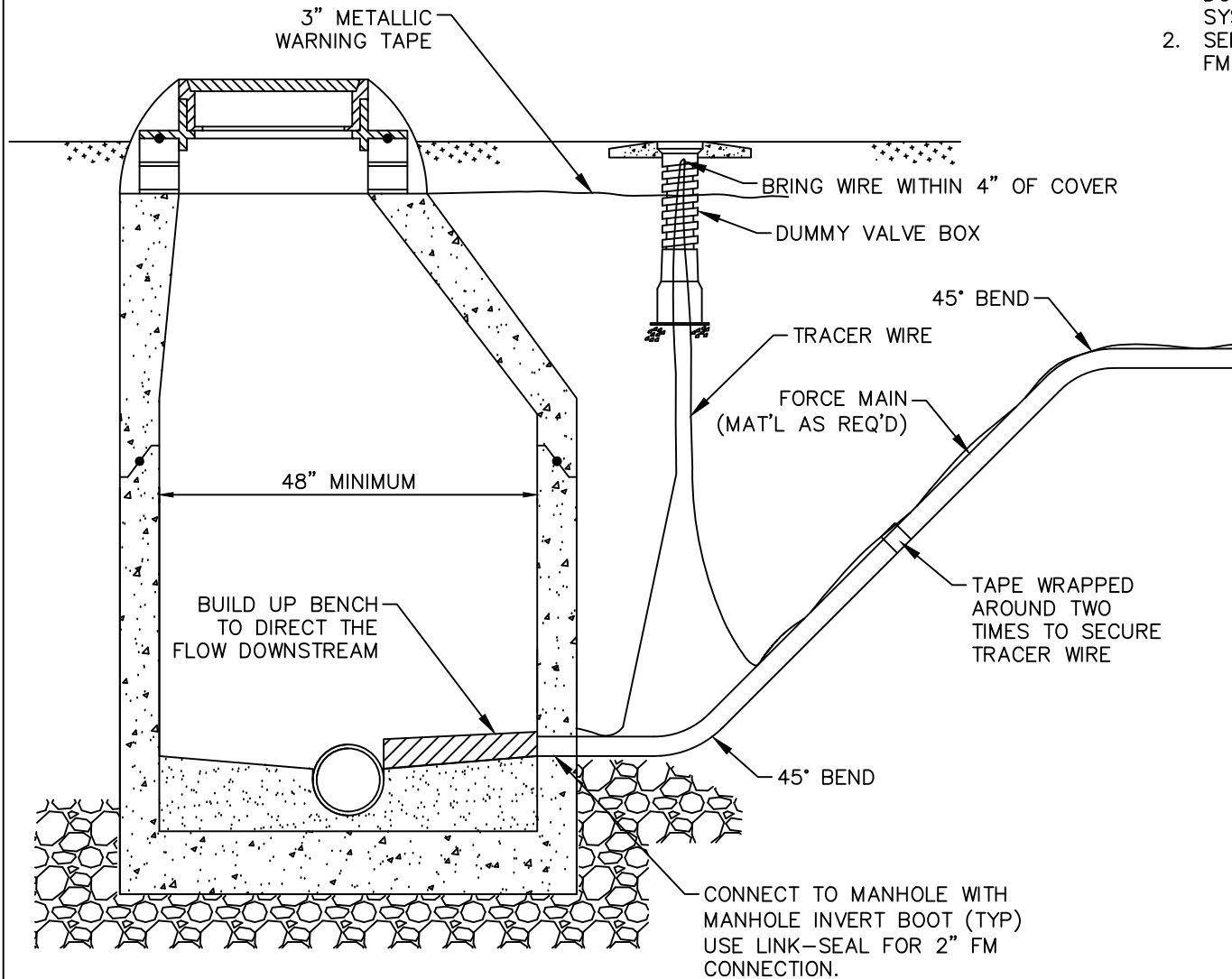

PLAN VIEW OF INVERT

TYPICAL FORCE MAIN CONNECTION DETAIL  
N.T.S.



7255 STALL ROAD, NORTH CHARLESTON, SC 29406  
PH: (843) 764-3072 FAX: (843) 764-2655

**N.C.S.D. STANDARD DETAILS**

REV. DATE: JUNE 2019      DWG#: FM-005